

the **GENERAL RADIO** Experimenter



© 1958 • GENERAL RADIO Company, Cambridge, Mass., U.S.A.

Since 1915 – Manufacturers of Electronic Apparatus for Science and Industry

VOLUME 32 No. 18

NOVEMBER, 1958



In This Issue

1-Mc Capacitance Measuring Assembly
1-Mc Oscillator
Variable Air Capacitor
Automatic Capacitance Bridge

the GENERAL RADIO Experimenter



Published Monthly by the General Radio Company

VOLUME 32 • NUMBER 18

NOVEMBER, 1958

CONTENTS

	Page
Complete Assembly for Capacitance Measurements at One Megacycle	3
A New, 1-Mc Unit Oscillator	4
Type 1421 Variable Air Capacitors	5
An Automatic Capacitance Bridge	6
Smithsonian Institution	8

The General Radio EXPERIMENTER is mailed without charge each month to engineers, scientists, technicians, and others interested in electronic techniques in measurement. When sending requests for subscriptions and address-change notices, please supply the following information: name, company address, type of business company is engaged in, and title or position of individual.

GENERAL RADIO COMPANY

275 Massachusetts Avenue, Cambridge 39, Mass.

Telephone: TRowbridge 6-4400

- NEW YORK:** Broad Avenue at Linden, Ridgefield, New Jersey
Telephone — N. Y., WOrth 4-2722
N. J., WHitney 3-3140
- CHICAGO:** 6605 West North Avenue, Oak Park, Illinois
Telephone — VillAge 8-9400
- PHILADELPHIA:** 1150 York Road, Abington, Pennsylvania
Telephone — HAncock 4-7419
- WASHINGTON:** 8055 13th St., Silver Spring, Maryland
Telephone — JUniper 5-1088
- LOS ANGELES:** 1000 North Seward St., Los Angeles 38, Calif.
Telephone — HOLlywood 9-6201
- SAN FRANCISCO:** 1182 Los Altos Ave., Los Altos, Calif.
Telephone — WHitecliff 8-8233
- CANADA:** 99 Floral Parkway, Toronto 15, Ontario
Telephone — CHerry 6-2171

REPAIR SERVICES

- EAST COAST:** General Radio Co., Service Dept., 22 Baker Avenue,
West Concord, Mass.
Telephone — Concord, EMerson 9-4400
Lincoln, CLearwater 9-8900
- MIDWEST:** General Radio Co., Service Dept., 6605 West North
Ave., Oak Park, Illinois
Telephone — VillAge 8-9400
- WEST COAST:** Western Instrument Co., 826 North Victory Boule-
vard, Burbank, Calif.
Telephone — VICToria 9-3013
- CANADA:** Bayly Engineering, Ltd., First St., Ajax, Ontario
Telephone — Toronto EMpire 2-3741

COVER



Testing of coaxial devices can be speeded up greatly through the use of the General Radio Motor-Driven Slotted Line. The photograph shows this line in use in the General Radio laboratories to test coaxial elements for standing-wave ratio.



COMPLETE ASSEMBLY FOR CAPACITANCE MEASUREMENTS AT ONE MEGACYCLE

Both commercial and military specifications for capacitors of 1000 $\mu\mu\text{f}$ and less call for measurement of capacitance and dissipation factor at a frequency of one megacycle. The TYPE 1610-AH Capacitance Measuring Assembly is a complete set of equipment for making these as well as other 2-terminal measurements.

Accessories are available which enhance the usefulness and convenience of the assembly for specific measurements. For the measurement of small capacitors, particularly disc-ceramic types, the TYPE 1691-A Capacitor Test Fixture is recommended. With the TYPE 1690-A Dielectric Sample Holder, specimens of dielectric materials in the form of ASTM 2-inch or smaller discs can be measured.

The TYPE 1610-AH Capacitance Measuring Assembly consists of:

- TYPE 716-CS1 Capacitance Bridge
- TYPE 1214-M 1-Mc Unit Oscillator
- TYPE 1212-A Unit Null Detector
- TYPE 1212-P1 1-Mc Filter
- TYPE 1203-B Unit Power Supply
- TYPE 480-P5UC1 and TYPE 480-P4U3 Adaptor Panels
- Relay Rack Cabinet
- Connection Cables and Power Cord

Although calibrated for a frequency of one megacycle, the bridge itself can be used at any frequency between 0.1

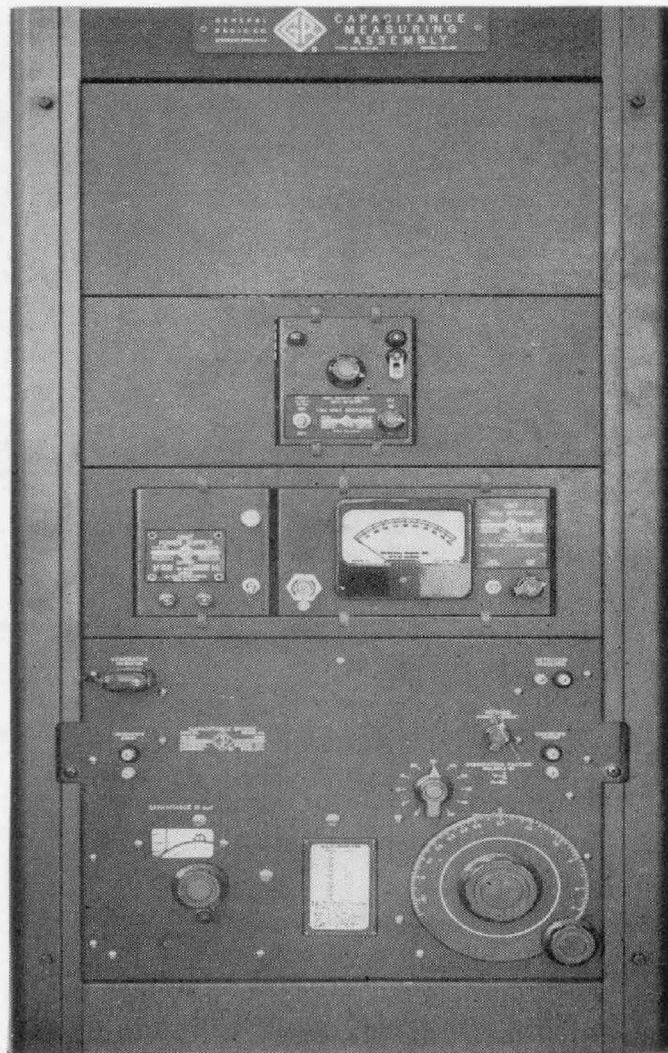

and 5 megacycles. A variable-frequency oscillator such as the TYPE 1211-B and a tunable selective detector (or radio receiver) are then required. If corrections are applied, rated accuracy can be attained.

SPECIFICATIONS

Capacitance Range: Direct Method, 100 to 1150 $\mu\mu\text{f}$; Substitution Method, 0.1 to 1050 $\mu\mu\text{f}$.

Dissipation Factor Range: Direct Method, 0.00002 to 0.56; Substitution Method, 0.00002 x

$\frac{C'}{C_x}$ to $0.56 \times \frac{C'}{C_x}$ where C' is the capacitance of the internal standard capacitor at initial balance and C_x that of the unknown.

Accuracy (at one megacycle):

Direct Reading: Capacitance, $\pm 0.1\% \pm 1 \mu\mu\text{f}$ when the dissipation factor of the unknown is less than 0.01; Dissipation Factor, ± 0.0005 or $\pm 2\%$ of dial reading, whichever is larger, for values of *D* below 0.1.

Substitution Method: Capacitance, $\pm 0.2\%$ or $\pm 2 \mu\mu\text{f}$, whichever is larger; Dissipation Factor, ± 0.00005 or $\pm 2\%$ of the change in *D* observed, when the change is less than 0.06.

When the dissipation factor of the unknown exceeds the limits given above, additional errors occur in both capacitance and dissipation-factor readings. Correction formulae are supplied, by means of which the accuracy given above can be maintained.

A correction chart for the precision capacitor is supplied, giving scale corrections to $0.1 \mu\mu\text{f}$ at multiples of $100 \mu\mu\text{f}$. By using these data, substitution measurements can be made to $\pm 0.1\%$ or $\pm 0.8 \mu\mu\text{f}$, whichever is the larger. For capacitances less than $25 \mu\mu\text{f}$, the error will decrease linearly to $\pm 0.1 \mu\mu\text{f}$. It is also

possible to obtain, at an extra charge, a worm-correction calibration with which substitution measurements can be made to an accuracy of 0.1% or $\pm 0.2 \mu\mu\text{f}$, whichever is the larger.

This same accuracy can be obtained with the bridge at other frequencies between 0.1 Mc and 3 Mc, if corrections are made for the effects of residual impedance, and if adequate selectivity is provided for the null detector.

Accessories Available: TYPE 1690-A Dielectric Sample Holder and TYPE 1691-A Capacitor Test Fixture.

Power Supply: 105 to 125 volts, 50 to 60 cycles, 100 watts input at 115 v line. Instrument will operate satisfactorily on power-supply frequencies up to 400 cycles, provided that the supply voltage is at least 115 volts.

Power input receptacle will accept either 2-wire (TYPE CAP-35) or 3-wire (TYPE CAP-15) power cord. Two-wire cord is supplied.

Dimensions: (Height) 43 x (width) $22\frac{1}{2}$ x (depth) 20 inches, over-all.

Net Weight: 150 pounds, approximately.

Type		Code Word	Price
1610-AH	Capacitance Measuring Assembly.....	SIREN	\$995.00
	Worm-Correction Calibration for Internal Precision Capacitor.....	WORMY	50.00
1690-A	Dielectric Sample Holder.....	LOYAL	435.00
1691-A	Capacitor Test Fixture.....	EDICT	22.50

A NEW, 1-MC UNIT OSCILLATOR

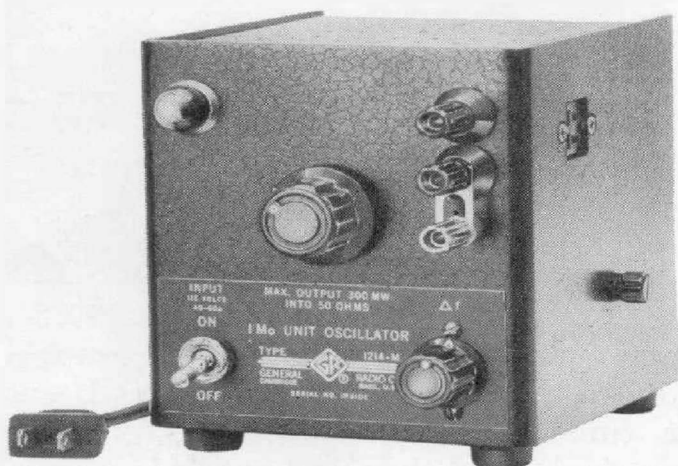

The TYPE 1214-M Unit Oscillator is another of General Radio's line of compact, inexpensive Unit Instruments. This oscillator generates a frequency

of 1 megacycle per second and is a useful power source for bridge measurements at that frequency. The TYPE 1214-M is the oscillator supplied with the TYPE 1610-AH Capacitance Measuring Assembly.

This oscillator uses a Hartley circuit and is designed for low distortion and high output level. The output can be isolated from ground. A continuous rotary control on the panel of the instrument varies the frequency over a range of $\pm 1\%$, while a second control varies the output from zero to maximum.

The built-in transformerless power supply operates from a 115-volt, 40- to 60-cycle ac line.

SPECIFICATIONS

Frequency: 1 Mc.
Frequency Accuracy: $\pm 1\%$.

Maximum Output: 300 mw into 50 ohms.
Open Circuit Output Voltage: 7 volts.



Distortion: 3.5% with 50-ohm load.

Power Input: 115 v, 40-60 cps.

Power Consumption: 12 watts.

Dimensions: (Height) $5\frac{3}{4}$ x (width) 5 x (depth) $6\frac{1}{4}$ inches.

Weight: $2\frac{3}{4}$ pounds.

Type		Code Word	Price
1214-M	Unit Oscillator, 1 Mc.	ATONE	\$75.00

TYPE 1421 VARIABLE AIR CAPACITORS

The TYPE 1421-J and TYPE 1421-K Variable Air Capacitors are new units in the General Radio line of instrument-type, parallel-plate air capacitors. These capacitors are machined from solid metal, in the same manner as the TYPE 1420 Capacitors.¹ This unique method of construction has many advantages, both electrical and mechanical, over conventional construction methods. Some of these added features are:

Better control of thickness and straightness of plates, since machining is a more precise operation than rolling.

Elimination of cumulative spacing errors by gang milling.

Better concentricity insured by turning and boring a single piece.

Sturdier structure with high mechanical stability, resulting from the integral-plate construction.

Good linearity and control of capacitance magnitude, insured by precise machining.

Lower metallic resistance and inductance and low thermal drift, because all the conducting material is homogeneous.

Minimum microphonic tendencies, due to the ruggedness of the plates.

Elimination of irregularities in the capacitance-vs.-rotation curve, because the stator plates are completely joined on their outer peripheries.

Elimination of crazing or other structural failure of the polystyrene dielectric, because the insulators are machined from a cast bar of cross-linked polystyrene for thermal adequacy and are stressed entirely in compression over a wide area.

Insured concentricity of the rotor, since the plates are milled and turned on a centered arbor held by the setscrews exactly as the shaft is secured in assembly.

¹ H. M. Wilson, "Type 1420 Variable Air Capacitor," *General Radio Experimenter*, Vol. 31, No. 2, July, 1956, pp. 7-10.

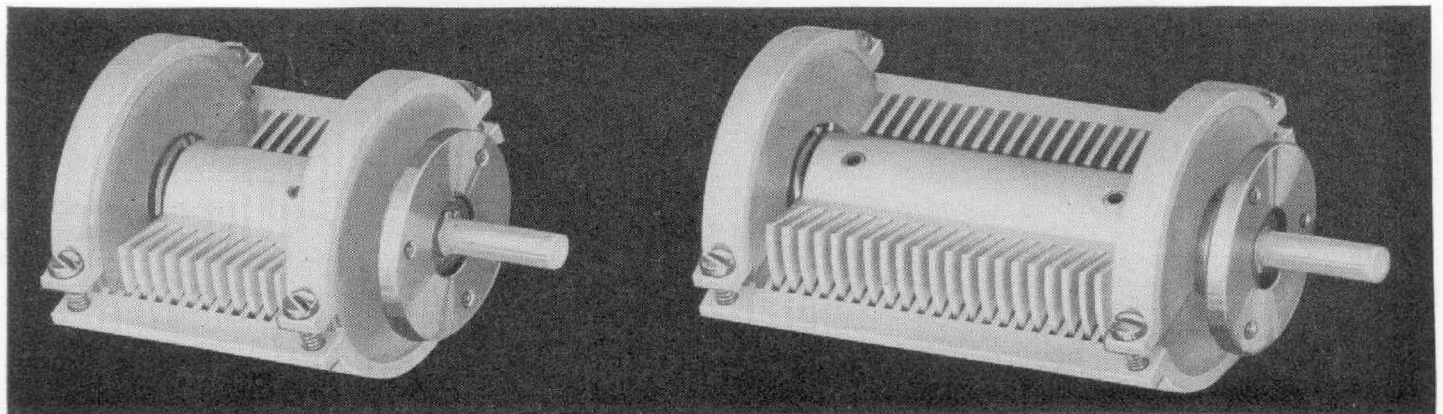

SPECIFICATIONS

Capacitance Range:

	Nominal	Min.	Range for Linear variation
J	575	22	540 ± 20 μμf
K	1120	29	1025 ± 25 μμf

The rotor-to-ground capacitance is about 2.5 μμf, and the stator-to-ground capacitance is about 4 μμf, for all sizes. The data in the above table are for the capacitor used as a two-terminal device, with rotor grounded. If stator is grounded, maximum and minimum capacitance values will be decreased by about 4 μμf.

Independent Linearity: The variation of capacitance with angle of rotation does not exceed ±0.3% of full scale. The angular range of linear variation is 160°.

Typical linearity is better than ±0.15%.

Dielectric Losses: For the grounded-rotor connection, the dielectric losses correspond to a D_oC_o product of less than .01 x 10⁻¹². The rotor-to-ground capacitance has a D_oC_o product of 0.1 x 10⁻¹². This loss component is in parallel with the main capacitance only for the grounded-stator connection.

Insulation Resistance: Greater than 10¹¹ ohms under standard ASTM laboratory conditions (23°C, 50% RH).

Temperature Coefficient of Capacitance: Approximately +.003% per degree C.

Maximum Voltage: 700 volts peak.

Torque: 2 ounce-inches, maximum, with shaft vertical.

Net Weight: TYPE 1421-J, 1 pound, 8 ounces; TYPE 1421-K, 1 pound, 14 ounces.

Dimensions: See sketch.

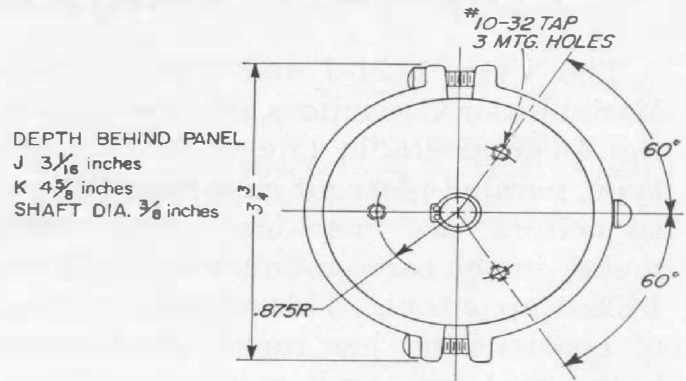

Type		Code Word	Price
1421-J	575 μμf, max.....	NABIR	\$46.50
1421-K	1120 μμf, max.....	NABOB	50.00

AN AUTOMATIC-BALANCING CAPACITANCE BRIDGE

The Automatic Capacitance Indicator (Figure 2) produced by Barnes Development Company is a self-balancing unit, which automatically indicates capaci-

tance and dissipation factor in an average time of 7 seconds. This instrument will measure capacitance from 100 μμf to 1.1 μf in four ranges, and dissipation

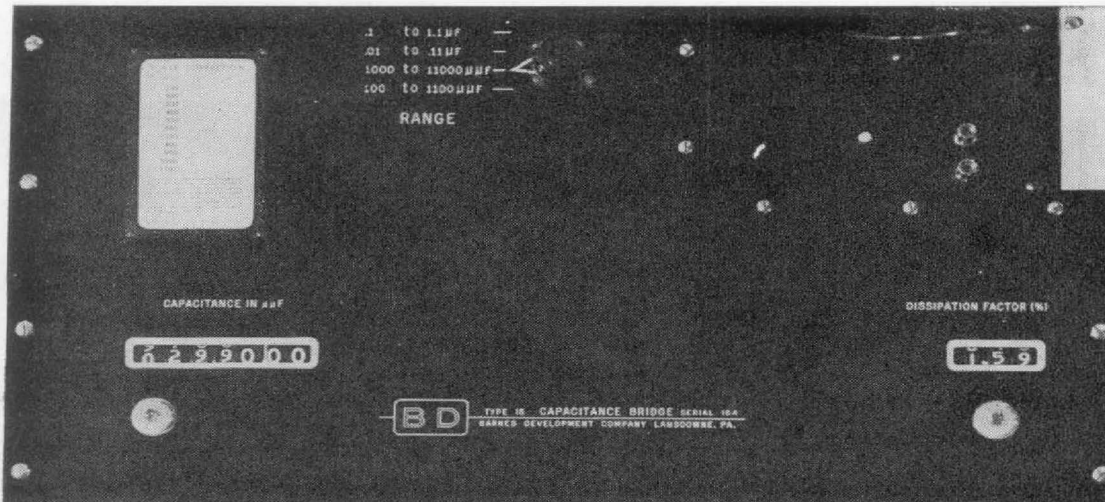

Figure 1. Panel view of the Barnes Automatic-Balancing Capacitance Bridge.



Figure 2. View of the complete bridge assembly.

factor from 0 to 16% in three ranges.

The basic bridge of the indicator is a General Radio TYPE 716-C Capacitance Bridge. Servo motors operating through gears accomplish the automatic

balancing. The accuracy of the automatic unit is equal to that of the capacitance bridge (capacitance, $\pm 0.1\% \pm 1 \mu\mu\text{f} \times$ capacitance multiplier setting) when the dissipation factor of the unknown is less than 0.01; dissipation factor, ± 0.0005 or $\pm 2\%$ of dial reading, whichever is the larger, for values of D below 0.1.

The block diagram of the Barnes Automatic Capacitance Bridge is shown in Figure 3. The error signal from the detector terminals is separated to feed the two channels for "C" and "D" balances. The "C" channel is driven through an attenuator; the "D" channel is fed directly.

After passing through voltage amplifiers the signals are fed to phase detectors. Phase discrimination is achieved by determination of the phase reference voltage fed to the phase detectors. The "C" detector receives an in-phase reference while the "D" detector receives a quadrature voltage.

The outputs of the phase detectors are filtered and then inverted into phase-reversible 60-cycle voltages by synchronous choppers. After power-amplification, these signals are impressed on the control winding of the two-phase servo motors controlling the "C" and "D" channels.

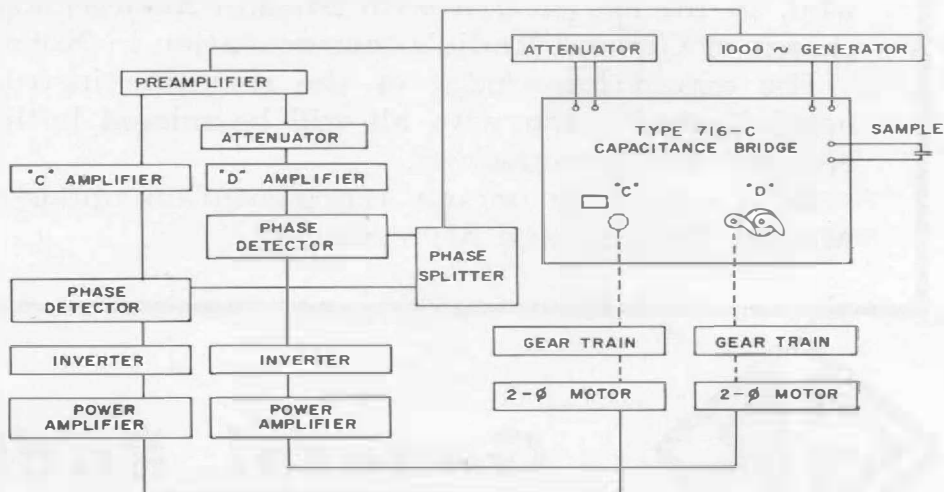

Figure 3. Block diagram of the automatic capacitance bridge.



The balance point is indicated by pilot lights, and the reading is presented directly as a row of figures, with automatically placed decimal points. The Automatic Capacitance Indicator is available with digital readout for use with any punched card or tape data system, or with servo (voltage) readout for producing a graphic record of values

with recorders. The bridge is available with either manual or automatic range switching of the capacitance and dissipation-factor ranges.

Inquiries about this bridge should be directed to the Barnes Development Company, 213 West Baltimore Pike, Lansdowne, Pennsylvania.

SMITHSONIAN INSTITUTION TO COLLECT EARLY COMMUNICATIONS EQUIPMENT

As many of our readers know, the famed Smithsonian Institution in Washington has begun an interesting collection of early communications equipment. A good start has already been made.

The Institution is now especially interested in considering for permanent display donations of early wireless equipment dating from the World War I period or earlier and limited to an arc transmitter, an induction coil spark transmitter and all kinds of measuring equipment. In the latter category, we

are planning to make several contributions from our own collection. Any of our readers who own or know of the existence of any of these types of pioneer apparatus are urged to communicate with the Editor or directly with the Curator, Division of Electricity, Smithsonian Institution, Washington 25, D. C.

The exhibit will eventually be housed in a new building under construction in Washington.

Early catalogs of old radio equipment are also desired for the historical library.

It is with deep regret that we report the death of Mr. G. Hammerik who, in his association with Maskin-Aktieselskapet Zeta of Oslo, was in charge of General Radio's representation in Norway.

His expert knowledge of the scientific instrumentation field and his helpful cooperation with all will be missed both by his many friends in Norway and by ourselves.

Zeta will carry on our representation under the capable direction of Messrs. Braenne and Myrseth.



General Radio Company